

# Smartgen<sup>®</sup>

## HGM6510 Genset Parallel Unit

### USER MANUAL

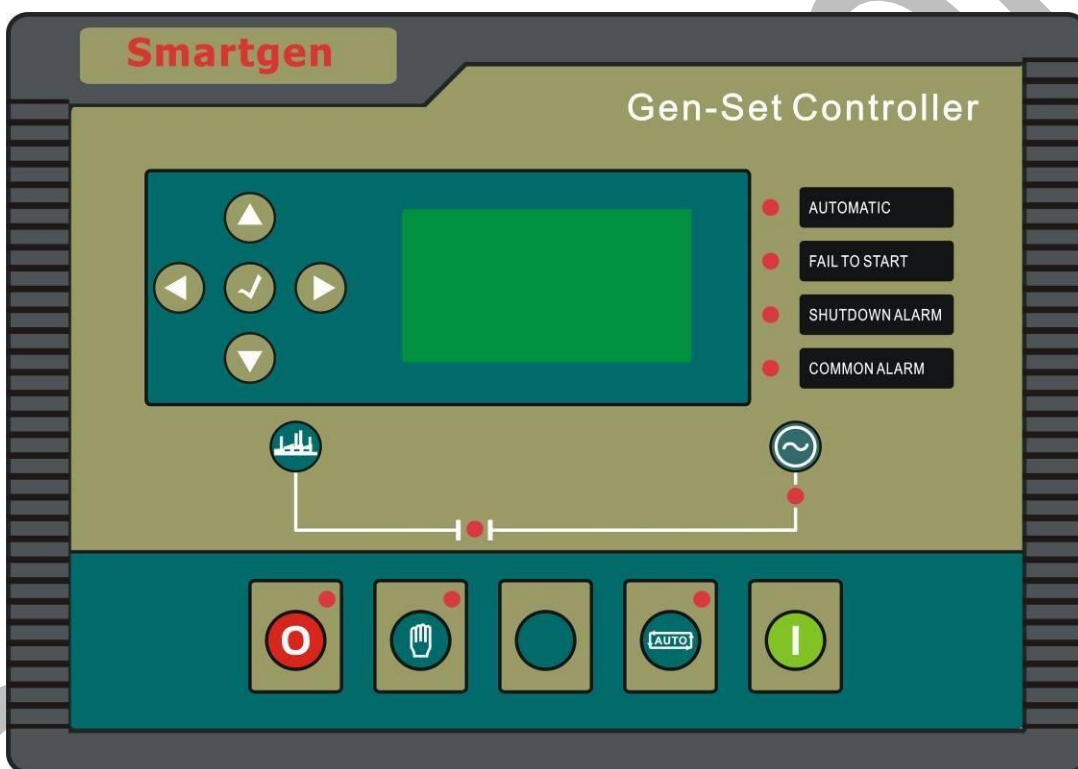

Smartgen Technology

## CONTENTS

1	OVERVIEW .....	6
2	PERFORMANCE AND CHARACTERISTICS .....	7
3	SPECIFICATION .....	10
4	FRONT PANEL .....	11
4.1	INDICATOR LIGHT .....	11
4.2	PUSHBUTTONS .....	12
5	OPERATION .....	13
5.1	AUTOMATIC OPERATION (MULTIPLE SETS) .....	13
5.2	MANUAL OPERATION (MULTIPLE SETS) .....	14
6	PROTECTIONS .....	16
6.1	WARNING ALARMS .....	16
6.2	SHUTDOWN ALARMS .....	19
6.3	TRIP AND STOP ALARMS .....	23
7	PANEL CONFIGURATION .....	26
7.1	LCD DISPLAY .....	26
7.1.1	STATUS DISPLAY .....	26
7.1.2	ENGINE DISPLAY .....	27
7.1.3	GENERATOR DISPLAY .....	27
7.1.4	BUS DISPLAY .....	28
7.1.5	SYNCHRONIZATION DISPLAY .....	28
7.1.6	ALARM DISPLAY .....	28
7.1.7	EVENT LOG .....	29
7.1.8	“ABOUT” DISPLAY .....	29
7.2	PARAMETER CONFIGURATION .....	29
7.3	DATE/TIME SETTING .....	34
7.4	DATA DISPLAY .....	34
7.4.1	BASIC DISPLAY .....	34
7.4.2	ECU DISPLAY .....	35
8	INPUT AND OUTPUT PORTS CONFIGURATION .....	36
8.1	CONFIGURABLE INPUT PORTS 1~9 .....	36
8.2	CONFIGURABLE OUTPUT PORTS 1-5 .....	38
9	EVENT LOG .....	42
10	BACK PANEL .....	42
11	ECU INTERFACE .....	45
12	DEBUGGING PROCEDURE .....	45
12.1	STEP 1. SINGLE UNIT DEBUGGING .....	45

---

12.2	STEP 2: MANUAL PARALLEL OPERATION OFF-LOAD .....	46
12.3	STEP 3: MANUAL PARALLEL OPERATION ON-LOAD .....	46
12.4	STEP 4: FULLY AUTOMATIC PARALLEL OPERATION.....	46
13	POWER MANAGEMENT MODE .....	48
14	TROUBLESHOOTING .....	49
15	TYPICAL WIRING DIAGRAMS .....	50
15.1	HGM6510 TYPICAL WIRING DIAGRAM .....	50
15.2	HGM6510 MAINS PARALLEL APPLICATION .....	50
15.3	HGM6510 MULTI-SET PARALLEL APPLICATION.....	51
16	COMMUNICATION INTERFACE .....	52
17	CASE DIMENSIONS AND PANEL CUTOUT.....	52

SmartGen

## 1 OVERVIEW

**HGM6510** controller is designed for manual/auto parallel systems of up to 20 generators with similar or different capacity. Additionally, it is suitable for single unit constant power output and mains paralleling. It allows automatic start/stop, data measurement, alarm protection as well as remote control, remote measurement and remote communication function. It fits with LCD display, optional languages interface, and it is reliable and easy to use.

Utilizing the GOV (Engine Speed Governor) and AVR (Automatic Voltage Regulator) control function, the controller is able to synchronize and share load automatically; it can be used to parallel with other HGM6510 controller.

**HGM6510** controller also monitors the engine, indicating the operational status and fault conditions accurately. When abnormal condition occurs, it splits bus and shuts down the genset, simultaneously the exact failure mode information is indicated by the LCD display on the front panel.

The powerful 32-bit Microprocessor contained within the module allows for many features to be incorporated as standard. SAE J1939 interface enables the controller to communicate with various ECU (ENGINE CONTROL UNIT) which fitted with J1939 interface. Multiple parameters such as engine speed, water temperature, oil temperature, and oil pressure can be transmitted via J1939 interface and displayed on LCD, so there is no need to install additional sensors and complicated wiring is avoided while electric parameters accuracy is ensured.

## 2 PERFORMANCE AND CHARACTERISTICS

- 2 application modes:
  - 1) Multi-set parallel operation;
  - 2) Single unit (constant power output) parallel with mains.
- 32-bit ARM microprocessor, LCD display with backlight, optional languages interface, push-button operation;
- Complete monitoring functions: almost all generator electric/non-electric parameters are monitored, as follows:

### Generator electric parameters:

3-phase phase voltage $U_a, U_b, U_c$	Unit: V
3-phase line voltage $U_{ab}, U_{bc}, U_{ca}$	Unit: V
3-phase current $I_a, I_b, I_c$	Unit: A
Frequency F1	Unit: Hz
Split phase active power $P_A, P_B, P_C$	Unit: kW
Total phase active power P	Unit: kW
Split phase reactive power $R_A, R_B, R_C$	Unit: kVar
Total phase reactive power P	Unit: kVar
Split phase apparent power $S_A, S_B, S_C$	Unit: kVA
Total phase apparent power S	Unit: KVA
Split phase power factor PF1, PF2, PF3	
Average power factor APF	
Total active energy	Unit: kWh
Total reactive energy	Unit: kVarh
Total apparent energy	Unit: kVAh
3-phase voltage phase sequence and phase angle	

### Bus/mains electricity parameters:

3-phase phase Voltage $U_a, U_b, U_c$	Unit: V
3-phase line Voltage $U_{ab}, U_{bc}, U_{ca}$	Unit: V
Frequency F1	Unit: Hz
3-phase voltage phase sequence and phase angle	

### Synchronization parameters:

Voltage difference between generator and bus/mains  
 Phase angle difference between generator and bus/mains  
 Frequency difference between generator and bus/mains

**Generator abnormal conditions:**

Over Voltage

Under Voltage

Over Frequency

Under Frequency

Loss of Phase

Phase Sequence Wrong

No power

**Fault display and alarm:**

High temperature warn

High temperature shutdown

Low oil pressure warn

Low oil pressure shutdown

Over speed shutdown

Low fuel level warn

Start battery over voltage warn

Start battery under voltage warn

Over current shutdown

Fail to start alarm

Fail to stop alarm

Emergency shutdown

Close fault

Open fault

Oil pressure sensor open circuit alarm

Reverse power

Phase sequence wrong

ECU Com fail

.....

- A number of options exist for the Auto Mode: off-load running, on-load running , demand parallel running;
- Ramp on and ramp off function;
- Weekly and monthly start/stop; on-load (parallel operation)/off load commissioning;
- SAE J1939 interface for ECU engine monitoring;
- True R.M.S. voltage monitoring function makes it suitable for multiple abnormal electric quantity situations;

- Accurately measure and display the electric parameters as well as water temperature, oil pressure, fuel level and others;
- Control and protection: Genset automatic start/stop/parallel operation, synchronization detection, load sharing and alarm protection;
- Maintenance function, maintenance due warning/shutdown alarm;
- For the engines without J1939: temperature, pressure and fuel level sensors can be connected externally; multiple ready to use and user-defined sensor curves;
- Free adjustment of input port information that is displayed on LCD when the input port is active: Chinese/English support, 20 English letters or 10 Chinese characters maximum;
- Close to activate/open to activate configurable input port types; normally open/normally closed configurable output port types;
- Custom logic output;
- Real-time calendar, real-time clock and total run counter;
- 99 event logs can be saved circularly and can be inquired on the spot.
- Multi-level password protection to avoid misuse by non-qualified personnel;
- Genset parameters can be adjusted from front panel or via PC;
- Wide power supply range DC(8-35)V enables compatibility with different start battery voltage environment;
- RS485/232C communication interface utilizing MODBUS protocol enables remote control, remote measurement, remote communication and remote adjustment of the genset;
- Modular design, anti-flaming ABS plastic enclosure, pluggable connection terminals and embedded installation way; compact structure with easy mounting.

### 3 SPECIFICATION

Parameter	Details
Working Voltage	DC8. 0V to 35. 0V, Continuous Power Supply.
Overall Consumption	<3W (Standby mode: ≤2W)
Alternator Voltage Input: 3 Phase 4 Wire 3 Phase 3 Wire Single Phase 2 Wire 2 Phase 3 Wire	AC15V - AC360V (ph-N) AC30V - AC600V (ph-ph) AC15V - AC360V (ph-N) AC15V - AC360V (ph-N)
True RMS Accuracy	1%
Alternator Frequency	50Hz/60Hz
Speed Sensor Voltage	1. 0 V to 24 V (RMS)
Speed Sensor Frequency	Maximum 10,000 Hz
Start Relay Output	16A DC28V power supply output
Fuel Relay Output	16A DC28V power supply output
Configurable Relay Output 1	16A DC28V power supply output
Configurable Relay Output 2	16A DC28V power supply output
Configurable Relay Output 3	16A DC28V power supply output
Configurable Relay Output 4	16A AC250V passive output
Configurable Relay Output 5	16A AC250V passive output
RS485 Interface	1500V Isolation; Maximum transmission distance: 1.2 kilometers; Baud rate:9600; Stop bits: 1 bit; Parity: No. Terminal matched resistance:120 Ω
RS232 Interface	Non-isolated Maximum transmission distance: 15 meters; Baud rate:9600; Stop bits: 1 bit; Parity: No.
MSC CAN Interface	1500V Isolation; Maximum transmission distance: 190 meters: Baud rate:330K; 250 meters: Baud rate:250K; 500 meters: Baud rate:125K; Terminal matched resistance:120 Ω
Case Dimensions	260mm x 182mm x 57mm
Panel Cutout	214mm x 160mm
CT Secondary Current	Rated 5A
Working Conditions	Temperature: (-25~+70)°C Humidity: (20~93)% without condensation







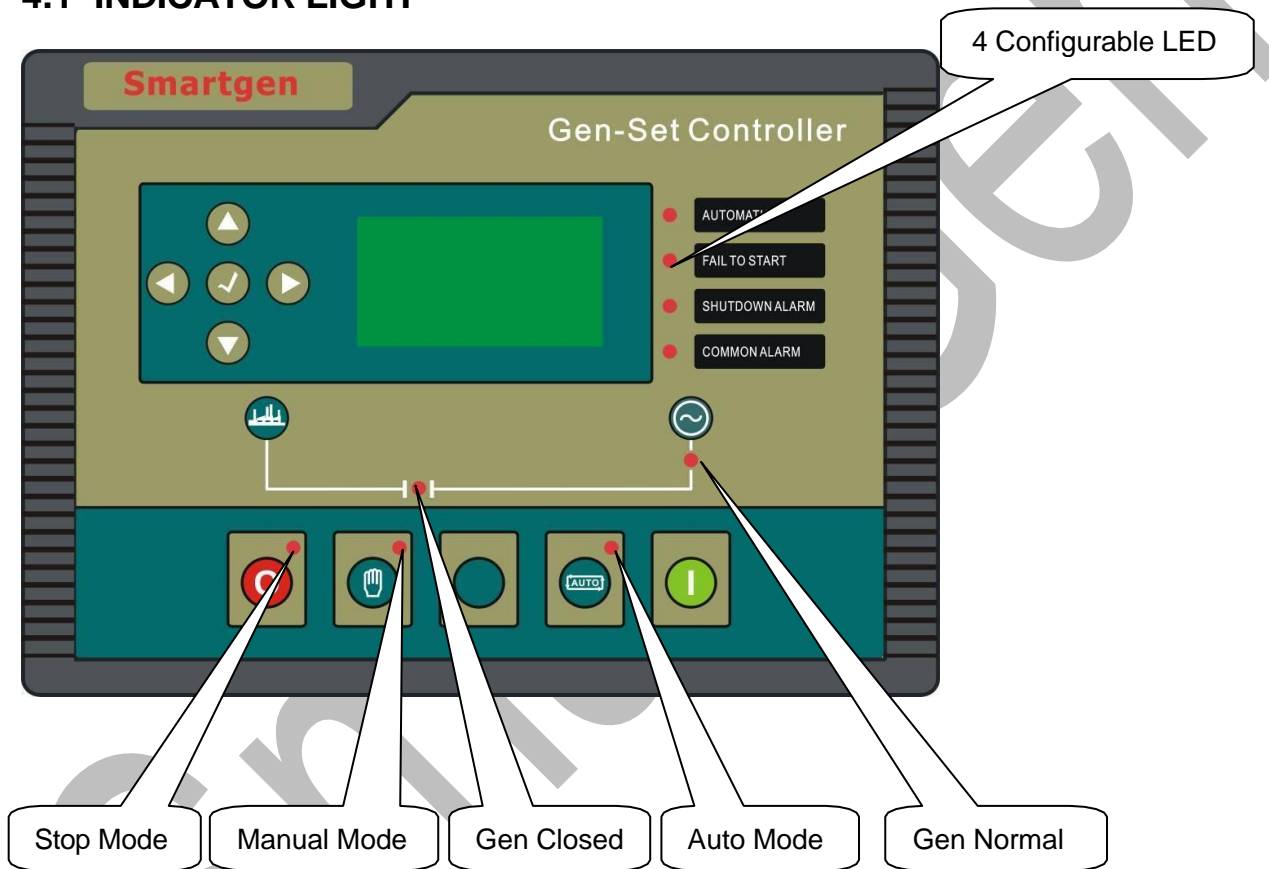





Parameter	Details
Storage Conditions	Temperature:(-40~+85)°C
Protection Level	IP55 Gasket
Insulation Intensity	Apply AC2.2kV voltage between high voltage terminal and low voltage terminal; The leakage current is not more than 3mA within 1min.
Weight	0.90kg

## 4 FRONT PANEL

### 4.1 INDICATOR LIGHT



## 4.2 PUSHBUTTONS

	Stop/Reset	When the genset is running, pressing this button will ramp off and stop running the generator; In case of alarm condition, pressing the button will reset alarm; In stop mode, pressing and holding the button for 3 seconds will test indicator lights (lamp test); During stopping process, press this button again to stop generator immediately.
	Start	In manual mode, pressing this button will start the gen-set (The button has effect in manual mode only)
	Manual	Press this key and controller enters in <b>Manual</b> mode.
		Reserved
	Auto	Press this key and controller enters in <b>Auto</b> mode.
	Gen Closed	In manual mode, when busbar has voltage, pressing the button will synchronize generator with bus and, after that, parallel generator with bus; when busbar has no voltage, pressing the key will close generator breaker immediately.
	Gen Open	In manual mode, when parallel mode is active, pressing the button will transfer load to other generators and then open breaker; when parallel mode is deactivated, pressing the button will open the breaker immediately.
	Up	Scrolls the screen up; Increase the set value in parameter setting menu.
	Down	Scrolls the screen down; Decrease the set value in parameter setting menu.
	Left	Scrolls the screen left; Move cursor left in parameter setting menu.
	Right	Scrolls the screen right; Move cursor right in parameter setting menu.
	Confirm	Confirm the set value in parameter setting menu.

## 5 OPERATION

### 5.1 AUTOMATIC OPERATION (MULTIPLE SETS)

Auto mode is selected by pressing the  button; a LED besides the button will illuminate to confirm the operation.

#### **Automatic Start Sequence:**

Configure one of the 9 configurable input ports as “Remote Start on Load Demand” using PC software. Remote Start on Load Demand input indicates to the controller that it should start the sets according to the pre-set priority procedure, and then, synchronize, parallel and share load with any other sets in the system automatically.

1. When “Remote Start” is active, “Start Delay” timer is initiated;
2. “Start Delay” countdown will be displayed on LCD;
3. When start delay is over, preheat relay energizes (if configured), “preheat delay XX s” information will be displayed on LCD;
4. After the above delay, the Fuel Relay (or ECU output if configured) is energized, and then one second later, the Start Relay is engaged. The engine is cranked for a pre-set time. If the engine fails to fire during this cranking attempt then the fuel relay and start relay are disengaged for the pre-set rest period; “crank rest time” begins and wait for the next crank attempt.

**▲NOTE: If the unit has been configured for CAN Bus, compatible ECU’s will receive the start command via CAN Bus.**

5. Should this start sequence continue beyond the set number of attempts, the start sequence will be terminated, the first line of LCD display will be highlighted with black and Fail to Start fault will be displayed.
6. In case of successful crank attempt, the “Safety On” timer is activated, allowing Low Oil Pressure, High Temperature, Under speed and Charge Alternator Failure inputs to stabilise without triggering the fault. As soon as this delay is over, “start idle” delay is initiated (if configured).

**▲NOTE: If the unit has been configured for CAN Bus, speed sensing is via CAN Bus.**

7. During “start idle” delay, under speed, under frequency, under voltage alarms are inhibited. When this delay is over, “warming up” delay is initiated (if configured).
8. In the case of a single generator system, after the “warming up” delay, if generator status is normal, its indicator will be illuminated. If generator voltage and frequency have reached on-load requirements, then the generator close relay will be energized;

genset will take load; generator power indicator will illuminate and generator will enter into Normal Running status. If voltage or frequency is abnormal, the controller will initiate shutdown alarm (alarm information will be displayed on LCD).



9. In case of running in parallel, after the warming up delay:

- a) If bus has no voltage, then the controller will send a closing signal to other waiting parallel gensets and generator close relay will activate, this prevents other sets in the system from attempting to close their own breakers at the same time.
- b) If bus has voltage or other gensets are already closed, the controller will adjust speed and voltage through GOV and AVR to synchronize the gensets to the bus; when synchronism requirements has been achieved, breaker close signal will be initiated and the genset will be paralleled with the bus. Once they are paralleled, the controller will control the generator to gradually accelerate and share load with other paralleled gensets.

#### **Automatic Stop Sequence,**

- 1) When the "Remote Start" signal is removed, the Stop Delay is initiated.
- 2) Once this "stop delay" has expired, the module will ramp the load from the generator to remaining set. The Generator Breaker will open and the "Cooling Delay" is then initiated. Should the Remote Start signal be re-activated during the cooling down period, the set will return parallel status. Once the "Cooling Delay" expires, the "Stop Idle" delay is initiated.
- 3) During "Stop Idle" Delay (if configured), idle relay is energized. If the unit has been configured for CAN Bus, stop command can be carried out via CAN Bus;
- 4) "ETS Solenoid Hold" begins, ETS relay is energized while fuel relay is de-energized.
- 5) "Fail to Stop Delay" begins, complete stop is detected automatically.
- 6) Generator is placed into its standby mode after its complete stop. Otherwise, fail to stop alarm is initiated and the corresponding alarm information is displayed on LCD.



## **5.2 MANUAL OPERATION (MULTIPLE SETS)**

1. Manual mode is selected by pressing the  button; a LED besides the button will illuminate to confirm the operation; then press  button to start the gen-set;
2. Preheat relay energizes (if configured), "preheat delay XX s" information will be displayed on LCD;
3. After the above delay, the Fuel Relay (or ECU output if configured) is energised, and then one second later, the Start Relay is engaged. The engine is cranked for a pre-set time. If the engine fails to fire during this cranking attempt then the fuel relay and start relay are disengaged for the pre-set rest period; "crank rest time" begins and wait for the next crank attempt.

**▲NOTE: If the unit has been configured for CAN Bus, compatible ECU"s will receive the start command via CAN Bus.**

4. Should this start sequence continue beyond the set number of attempts, the start sequence will be terminated, the first line of LCD display will be highlighted with black and Fail to Start fault will be displayed.
5. In case of successful crank attempt, the "Safety On" timer is activated, allowing Low Oil Pressure, High Temperature, Under speed and Charge Alternator Failure inputs to stabilise without triggering the fault. As soon as this delay is over, "start idle" delay is initiated (if configured).

**▲NOTE: If the unit has been configured for CAN Bus, speed sensing is via CAN Bus.**

6. During "start idle" delay, under speed, under frequency, under voltage alarms are inhibited. When this delay is over, "warming up" delay is initiated (if configured).
7. When "warming up" delay is over, the genset waits for taking load;
8. Press  button, in the case of a single generator system, after the "warming up" delay, if generator status is normal, its indicator will be illuminated. If generator voltage and frequency have reached on-load requirements, then the generator close relay will be energized; genset will take load; generator power indicator will illuminate and generator will enter into Normal Running status. if voltage or frequency is abnormal, the controller will initiate shutdown alarm (alarm information will be displayed on LCD).
9. If the  button is pressed while in parallel, after the warming up delay:
  - a) If bus has no voltage, then the controller will send a closing signal to other waiting parallel gensets and generator close relay will activate, this prevents other sets in the system from attempting to close their own breakers at the same time.
  - b) If bus has voltage or other gensets are already closed, the controller will adjust speed and voltage through GOV and AVR to synchronize the gensets to the bus; when synchronism requirements has been achieved, breaker close signal will be initiated and the genset will be paralleled to the bus. Once they are paralleled, the controller will control the generator to gradually accelerate and share load with other paralleled gensets.
10. If the  button is pressed while in parallel operation, the module will ramp the load on the remaining generators and then open the generator breaker.

## 6 PROTECTIONS

When an alarm is present, the Common Alarm LED (if configured) will illuminate and alarm information will be displayed on LCD.

### 6.1 WARNING ALARMS

Warnings are not shutdown alarms and do not affect the operation of the genset. Warning does not lead to shutdown, and when warning condition is no longer present, warning alarm will be cleared automatically. Warning types are as follows:

No	Type	Active Range	Description
1	Gen Over Current	Always active	When the controller detects that the genset current has exceeded the pre-set value, it will initiate a warning alarm and the corresponding alarm information will be displayed on LCD.
2	Fail To Stop	After "Fail to Stop" Delay	After "fail to stop" delay, if gen-set is still output electricity or oil pressure is not 0, it will initiate a warning alarm and the corresponding alarm information will be displayed on LCD.
3	Low Fuel Level	Always active	When the controller detects that the fuel level has fallen below the pre-set value, it will initiate a warning alarm and the corresponding alarm information will be displayed on LCD.
4	Charge Alternator Failure	From "Start Idle" delay to "Stop Idle" delay	When the controller detects that charger voltage has fallen below the pre-set value, it will initiate a warning alarm and the corresponding alarm information will be displayed on LCD.
5	Loss of Speed Signal	From "Crank Success" to "Stop Idle" delay	When the controller detects that the engine speed is 0, it will initiate a warning alarm and the corresponding alarm information will be displayed on LCD.
6	Battery Under Volt	Always active	When the controller detects that start battery voltage has fallen below the pre-set value, it will initiate a warning alarm and the corresponding alarm information will be displayed on LCD.
7	Battery Over Volt	Always active	When the controller detects that start battery voltage has exceeded the pre-set value, it will initiate a warning alarm and the corresponding alarm information will be displayed on LCD.

## HGM6510 GENSET PARALLEL UNIT

No	Type	Active Range	Description
8	Reverse Power	Always active	If reverse power detection is enabled, when the controller detects that the reverse power value (power is negative) has fallen below the pre-set value, it will initiate a warning alarm and the corresponding alarm information will be displayed on LCD.
9	Auxiliary Input 1-9	User defined	When the controller detects that the auxiliary input 1-9 warning signals, it will initiate a warning alarm and the corresponding alarm information will be displayed on LCD.
10	Maintenance Due	Always active	When engine total run time exceeds the pre-set maintenance time or pre-set days, it will initiate a warning alarm and the corresponding alarm information will be displayed on LCD. *1
11	Fail to sync time	When synchronization is enabled.	When the controller does not detect synchronization signal within the pre-set synchronization time, it will initiate a warning alarm and the corresponding alarm information will be displayed on LCD.
12	Gen Phase Sequence Wrong	When generator is normal	When the controller detects a phase rotation error (correct phase is L1, L2, L3), it will initiate a warning alarm and the corresponding alarm information will be displayed on LCD.
13	Bus Phase Sequence Wrong	When the bus is live	When the controller detects a bus phase rotation error (correct phase is L1, L2, L3), it will initiate a warning alarm and the corresponding alarm information will be displayed on LCD.
14	MSC Data Error	Always active	When the controller detects a problem on the MSC link which prevents the module from communicating correctly with the other modules, it will initiate a warning alarm and the corresponding alarm information will be displayed on LCD.
15	MSC Too Few Sets	Always active	When the controller detects fewer modules on the MSC link than the minimum number configured in the unit, it will initiate a warning alarm and the corresponding alarm information will be displayed on LCD.*2
16	ECU Warn	Always active	If an error message is received from ECU via CANBUS, it will initiate a warning alarm and the corresponding alarm information will be displayed on LCD.

HGM6510 GENSET PARALLEL UNIT

No	Type	Active Range	Description
17	Negative Sequence Current	When generator is closed	When the controller detects an imbalance in the load current of each phase above a pre-set level, it will initiate a warning alarm and the corresponding alarm information will be displayed on LCD.
18	High Temperature	From "Start Idle" delay to "Stop Idle" delay	When the controller detects that engine temperature has exceeded the pre-set value, it will initiate a warning alarm and the corresponding alarm information will be displayed on LCD.
19	Low Temperature	Always active	When the controller detects that engine temperature has fallen below the pre-set value, it will initiate a warning alarm and the corresponding alarm information will be displayed on LCD.
20	Low Oil Pressure	From "Start Idle" delay to "Stop Idle" delay	When the controller detects that the oil pressure has fallen below the pre-set value, it will initiate a warning alarm and the corresponding alarm information will be displayed on LCD.
21	Over Speed	Always active	When the controller detects that the engine speed has exceeded the pre-set value, it will initiate a warning alarm and the corresponding alarm information will be displayed on LCD.
22	Under Speed	From "Waiting for load" delay to "Cooling" delay	When the controller detects that the engine speed has fallen below the pre-set value, it will initiate a warning alarm and the corresponding alarm information will be displayed on LCD.
23	Gen Over Frequency	Always active	When the controller detects that the genset frequency has exceeded the pre-set value, it will initiate a warning alarm and the corresponding alarm information will be displayed on LCD.
24	Gen Under Frequency	From "Waiting for load" delay to "Cooling" delay	When the controller detects that the genset frequency has fallen below the pre-set value, it will initiate a warning alarm and the corresponding alarm information will be displayed on LCD.
25	Gen Over Voltage	Always active	When the controller detects that the generator voltage has exceeded the pre-set value, the controller will initiate a warning alarm signal and a warning message will be displayed on LCD.

No	Type	Active Range	Description
26	Genset Under Voltage	From “Waiting for load” delay to “Cooling” delay	When the controller detects that the genset voltage has fallen below the pre-set value, it will initiate a warning alarm and the corresponding alarm information will be displayed on LCD.
27	Loss of Excitation	During parallel operation	When the controller detects that the genset negative reactive power has exceeded the pre-set value, it will initiate a warning alarm and the corresponding alarm information will be displayed on LCD.
28	Oil Pressure Open Circuit	Always active	When the controller detects that the oil pressure sensor is open circuit and the action select “Warn”, it will initiate a warning alarm and the corresponding alarm information will be displayed on LCD.
29	Temperature Sensor Open Circuit	Always active	When the controller detects that the temperature sensor is open circuit and the action select “Warn”, it will initiate a warning alarm and the corresponding alarm information will be displayed on LCD.
30	Earth Fault Current	Always active	If earth fault detection is enabled, when the controller detects that the earth fault current has exceeded the pre-set value and the action select “Warn”, it will initiate a warning alarm and the corresponding alarm information will be displayed on LCD.
31	Over Power	Always active	If over power detection is enabled, when the controller detects that the over power value (power is positive) has exceeded the pre-set value, it will initiate a warning alarm and the corresponding alarm information will be displayed on LCD.

 **Notes :**

\*1: When maintenance time is due, set one of the input ports as “Reset Maintenance Alarm”, then the alarm will be cleared by sending an active grounding impulse signal.

\*2: There are 2 possible reasons:

- a) MSC Communication line between the controllers disconnects, which interrupts communication.
- b) Controllers of parallel gensets have no power supply.

## 6.2 SHUTDOWN ALARMS

Shutdown alarm must be cleared and the fault removed to reset the module. Alarms are

latching and stop the Generator.

No	Type	Range	Description
1	Emergency Stop	Always active	When the controller detects an emergency stop alarm signal, it will initiate a shutdown alarm and the corresponding alarm information will be displayed on LCD.
2	High Temperature	From "Start Idle" delay to "Stop Idle" delay	When the controller detects that water/cylinder temperature has exceeded the pre-set value, it will initiate a shutdown alarm and the corresponding alarm information will be displayed on LCD.
3	Low Pressure Oil	From "Start Idle" delay to "Stop Idle" delay	When the controller detects that the oil pressure has fallen below the pre-set value, it will initiate a shutdown alarm and the corresponding alarm information will be displayed on LCD.
4	Over Speed	Always active	When the controller detects that the generator speed has exceeded the pre-set value, it will initiate a shutdown alarm and the corresponding alarm information will be displayed on LCD.
5	Under Speed	From "Waiting for load" delay to "Cooling" delay	When the controller detects that the generator speed has fallen below the pre-set value, it will initiate a shutdown alarm and the corresponding alarm information will be displayed on LCD.
6	Loss of Speed Signal	From "Crank Success" to "Stop Idle" delay	When the controller detects that the genset speed is 0, it will initiate a shutdown alarm and the corresponding alarm information will be displayed on LCD.
7	Gen Over Frequency	Always active	When the controller detects that the genset frequency has exceeded the pre-set value, it will initiate a shutdown alarm and the corresponding alarm information will be displayed on LCD.
8	Gen Under Frequency	From "Waiting for load" delay to "Cooling" delay	When the controller detects that the genset frequency has fallen below the pre-set value, it will initiate a shutdown alarm and the corresponding alarm information will be displayed on LCD.
9	Gen Over Voltage	Always active	When the controller detects that the genset voltage has exceeded the pre-set value, it will initiate a shutdown alarm and the corresponding alarm information will be displayed on LCD.

HGM6510 GENSET PARALLEL UNIT

No	Type	Range	Description
10	Gen Under Voltage	From "Waiting for load" delay to "Cooling" delay	When the controller detects that the genset voltage has fallen below the pre-set value, it will initiate a shutdown alarm and the corresponding alarm information will be displayed on LCD.
11	Gen Over Current	Always active	When the controller detects that the genset current has exceeded the pre-set value, it will initiate a shutdown alarm and the corresponding alarm information will be displayed on LCD.
12	Fail To Start	If the engine does not fire after the pre-set number of attempts	If the engine does not fire after the pre-set number of attempts, it will initiate a shutdown alarm and the corresponding alarm information will be displayed on LCD.
13	Oil Pressure Open Circuit	Always active	When the controller detects that the oil pressure sensor is open circuit, it will initiate a shutdown alarm and the corresponding alarm information will be displayed on LCD.
14	Auxiliary Inputs 1-9	User-defined	When the controller detects that the auxiliary input 1-9 shutdown alarm signals, it will initiate a shutdown alarm and the corresponding alarm information will be displayed on LCD.
15	ECU Fail	After the engine is started, if the module is configured for CANbus operation.	If the module does not detect the ECU data, it will initiate a shutdown alarm and the corresponding alarm information will be displayed on LCD. This failure may be caused by CANbus open circuit, short circuit or wrong wiring.
16	Negative Sequence Current	After generator is closed	When the controller detects an imbalance in the load current above a pre-set level, it will initiate a shutdown alarm and the corresponding alarm information will be displayed on LCD.
17	ECU Warn	After the engine is started, if the module is configured for CANbus operation.	If shutdown alarm signal is received from ECU through CANbus, it will initiate a shutdown alarm and the corresponding alarm information will be displayed on LCD.
18	Gen Fail to Close	Always active	If the close signal was not be detected within the generator breaker close timer, it will initiate a shutdown alarm and the corresponding alarm information will be displayed on LCD.

HGM6510 GENSET PARALLEL UNIT

No	Type	Range	Description
19	Gen Fail to Open	Always active	If the open signal was not be detected within the generator breaker open timer, it will initiate a shutdown alarm and the corresponding alarm information will be displayed on LCD.
20	Maintenance Due	Always active	If maintenance is enabled, when maintenance countdown time is 0 and the action select "Shutdown", it will initiate a shutdown alarm and the corresponding alarm information will be displayed on LCD.
21	Gen Phase Sequence Wrong	When generator is normal	When the controller detects a phase rotation error (correct phase is L1, L2, L3), it will initiate a shutdown alarm and the corresponding alarm information will be displayed on LCD.
22	Bus Phase Sequence Wrong	When the bus is live	When the controller detects a bus phase rotation error (correct phase is L1, L2, L3), it will initiate a shutdown alarm and the corresponding alarm information will be displayed on LCD.
23	Reverse Power	Always active	If reverse power detection is enabled, when the controller detects that the reverse power value (power is negative) has fallen below the pre-set value, it will initiate a shutdown alarm and the corresponding alarm information will be displayed on LCD.
24	Over Power	Always active	If over power detection is enabled, when the controller detects that the over power value (power is positive) has exceeded the pre-set value, it will initiate a shutdown alarm and the corresponding alarm information will be displayed on LCD.
25	Loss of Excitation	Always active	If "Loss of Excitation" detection is enabled, when the controller detects that the genset negative reactive power has exceeded the pre-set value, it will initiate a shutdown alarm and the corresponding alarm information will be displayed on LCD.
26	Bus Fault	Before closing breaker	when the controller detects that the bus voltage is 0 and other sets are closed already, it will initiate a shutdown alarm and the corresponding alarm information will be displayed on LCD.

No	Type	Range	Description
27	Earth Fault Current	Always active	If "earth fault" detection is enabled, when the controller detects a generator earth fault current has exceeded the pre-set value and the action select "Shutdown", it will initiate a shutdown alarm and the corresponding alarm information will be displayed on LCD.

### 6.3 TRIP AND STOP ALARMS

On initiation of the trip condition the controller will de-energize the „Close Generator“ Output to remove the load from the generator. Once this has occurred the controller will start the Cooling delay and allow the engine to cool before shutting down the engine.

No	Type	Range	Description
1	Gen Over Current	Always active	When the controller detects that the genset current has exceeded the pre-set value, it will initiate a trip and stop alarm and the corresponding alarm information will be displayed on LCD. *1
2	Reverse Power	Always active	When the controller detects that the reverse power value has exceeded the pre-set value, it will initiate a trip and stop alarm and the corresponding alarm information will be displayed on LCD.
3	Loss Of Excitation	Always active	When the controller detects that the genset negative reactive power has exceeded the pre-set value, it will initiate a trip and stop alarm and the corresponding alarm information will be displayed on LCD.
4	Negative Sequence Current	After generator breaker is closed	When the controller detects an imbalance in the load current above a pre-set level, it will initiate a trip and stop alarm and the corresponding alarm information will be displayed on LCD.
5	Auxiliary Inputs 1-9	User-defined	When the controller detects that the auxiliary input 1-9 trip alarm signals, it will initiate a trip and stop alarm and the corresponding alarm information will be displayed on LCD.
6	MSC Error	When parallel operation is enabled	When the controller cannot detect other controller on the MSC link, it will initiate a trip and stop alarm and the corresponding alarm information will be displayed on LCD.
7	MSC Too Few Sets	Always active	If the module detects fewer modules on the MSC link than the minimum number configured in the unit, it will initiate a trip and stop alarm and the corresponding alarm information will be displayed on LCD.

HGM6510 GENSET PARALLEL UNIT

8	Mains Over Frequency	When mains parallel operation is enabled	When the controller detects that the mains frequency has exceeded the pre-set value, it will initiate a trip and stop alarm and the corresponding alarm information will be displayed on LCD.
9	Mains Under Frequency	When mains parallel operation is enabled	When the controller detects that the mains frequency has fallen below the pre-set value, it will initiate a trip and stop alarm and the corresponding alarm information will be displayed on LCD.
10	Mains Over Voltage	When mains parallel operation is enabled	When the controller detects that the mains voltage has exceeded the pre-set value, it will initiate a trip and stop alarm and the corresponding alarm information will be displayed on LCD.
11	Mains Under Voltage	When mains parallel operation is enabled	When the controller detects that the mains voltage has fallen below the pre-set value, it will initiate a trip and stop alarm and the corresponding alarm information will be displayed on LCD.
12	Mains ROCOF	When mains parallel operation is enabled	When the controller detects that the rate of change of frequency has exceeded the pre-set value, it will initiate a trip and stop alarm and the corresponding alarm information will be displayed on LCD.
13	Mains Vector Shift	When mains parallel operation is enabled	When the controller detects that the mains vector shift has exceeded the pre-set value, it will initiate a trip and stop alarm and the corresponding alarm information will be displayed on LCD.
14	Earth Fault Current	Always active	If "earth fault" detection is enabled, when the controller detects a generator earth fault current has exceeded the pre-set value and the action select "Trip and Stop", it will initiate a trip and stop alarm and the corresponding alarm information will be displayed on LCD.
15	Over Power	Always active	If over power detection is enabled, when the controller detects that the over power value (power is positive) has exceeded the pre-set value, and the action select "Trip and Stop", it will initiate a trip and stop alarm and the corresponding alarm information will be displayed on LCD.

16	Fail to sync	When synchronization is enabled	When the controller does not detect synchronization signal within the pre-set synchronization time, it will initiate a trip and stop alarm and the corresponding alarm information will be displayed on LCD.
17	Low Fuel Level	Always active	When the controller detects that the fuel level has fallen below the pre-set value, it will initiate a trip and stop alarm and the corresponding alarm information will be displayed on LCD.



**Note \*1:** Inverse Definite Minimum Time(IDMT) : overcurrent delay decrease with the increase of overcurrent value. Different overcurrent value has corresponding delay.

IDMT formula:

$$T = t / ((IA/IT)-1)^2$$

T: Overcurrent delay (second)

t: Timing multiplier ratio

IA: Current max. load current (L1/L2/L3)

IT: Overcurrent setting value

Example:

$$t = 36$$

$$IA = 550A$$

$$IT = 500A$$

Conclusion: T = 3600s(1hour)

For instance, if set Over Current as 100%, Timing multiplier ratio as 36. That is to say if the Gen Over Current has exceeds 100%, over current delay will be initiated; if the Gen Over Current is 110% and does not drop to normal levels within one hour, the breaker is opened and the genset is cooled down and stopped.

## 7 PANEL CONFIGURATION

### 7.1 LCD DISPLAY

#### 7.1.1 STATUS DISPLAY

STATUS 1-1	First Status Screen
STOP MODE	Controller Modes: STOP/MANUAL/AUTO Mode
GENSET AT REST	Genset Working Status
GENSET OPEN	Generator Breaker Status
STATUS 1-2	Second Status Screen
UL-N 0 V 0.0 A	Generator Average Phase Voltage/Current
UL-L 0V 0.00Hz	Generator Average Line Voltage/Frequency
Pf = 0.00L 0.0 kW	Generator Average Power Factor, Total Active Power
STATUS 1-3	Third Status Screen
F S E123456789	F: Fuel Output, S: Start Output, E: Emergency Stop, 1~9 auxiliary input ports, 1~5 output ports
INPUT	Input status: close/open
OUTPUT	Output status: close/open
STATUS 1-4	Forth Status Screen
MSC Total 3	Total number of modules
MSC ID 012	Module ID
Priority 012	Module priority

**7.1.2 ENGINE DISPLAY**

ENGINE	2-1	First Engine Screen
SPEED	0 RPM	Engine Speed
BATTERY	0.0 V	Generator Start Battery Voltage
CHARGE D+	0.0 V	AC Charger D+ Voltage
ENGINE	2-2	Second Engine Screen
OIL PRESSURE	0 kPa 0.0 Bar 0 Psi	Engine Oil Pressure
ENGINE	2-3	Third Engine Screen
FUEL LEVEL	0 %	Fuel Level
TEMPERATURE	0 °C 0 °F	Engine Temperature
ENGINE	2-4	Fourth Engine Screen
STARTS	00000 times	Total Start Times
HOURS RUN	00000:00:00	Total Run Time: HH: MM: SS
MAINTENANCE	00000h	The display of the remaining maintenance time

**7.1.3 GENERATOR DISPLAY**

GENERATOR	3-1	First Generator Screen
UL-L	0 0 0 V	3-phase Phase Voltage L1-N L2-N L3-N
UL-N	0 0 0 V	3-phase Line Voltage L1-L2 L2-L3 L3-L1
F =	0.00Hz 0 RPM	Generator Frequency, Engine Speed
GENERATOR	3-2	Second Generator Screen
IL	0.0 0.0 0.0 A	3-phase Current L1 L2 L3
PF	0.00 0.00 0.00	3-phase Power Factor L1 L2 L3
APF	0.00L 10 0.0 A	Generator Frequency Power Factor, Generator Zero Sequence Current
GENERATOR	3-3	Third Generator Screen
kW	0.0 0.0 0.0	3-phase Split-phase Active Power L1 L2 L3
TkW	0.0 Ramp 0.0	Generator Total Active Power, Pre-set Active Power Percentage
kW%	0.0 Tgt% 0.0	Active Power Output Percentage, Target Active Power Percentage
GENERATOR	3-4	Fourth Generator Screen
kVar	0.0 0.0 0.0	3-phase Reactive Power L1 L2 L3
TkVar	0.0 Ramp 0.0	Total Reactive Power, Pre-set Reactive Power Percentage
kVar%	0.0 Tgt% 0.0	Reactive Power Output Percentage, Target Reactive Power Percentage

<b>GENERATOR 3-5</b>	Fifth Generator Screen
kVA 0.0 0.0 0.0	3-phase Apparent Power L1 L2 L3
TkVA 0.0	Total Apparent Power
GOV% 0.0 AVR% 0.0	GOV Output Percentage, AVR Output Percentage
<b>GENERATOR 3-6</b>	Sixth Generator Screen
kWh 0000000.0	Total kW Energy
kVAh 0000000.0	Total kVA Energy
kVarh 0000000.0	Total kVar Energy
<b>GENERATOR 3-7</b>	Seventh Generator Screen
<b>PHASE-SEQUENCE:</b> LN1-LN2-LN3 000-120-240°	Generator Phase Sequence

**7.1.4 BUS DISPLAY**

<b>BUS 4-1</b>	First Bus Screen
UL-L 0 0 0 V	3-phase Phase Voltage L1-N L2-N L3-N
UL-N 0 0 0 V	3-phase Line Voltage L1-L2 L2-L3 L3-L1
F = 0.00Hz	Bus Frequency
<b>BUS 4-2</b>	Second Bus Screen
<b>PHASE SEQUENCE:</b> LN1-LN2-LN3 000-120-240°	Bus Phase Sequence

**7.1.5 SYNCHRONIZATION DISPLAY**

Remarks: “√” means the error value comply with standards while “X” means *NOT*.

<b>SYN 5-1</b>	First Synchronization Screen
 +0.1 V √	Voltage Difference between generator and bus
+0.01 Hz √	Frequency Difference between generator and bus
+0.1° √	Phase Angle Difference between generator and bus

**7.1.6 ALARM DISPLAY**

<b>ALARMS 6-1</b>	First Alarm Screen
ALARMS:(01/02)	Total Alarms
SHUTDOWN ALARM	Alarm Type: Warn/Shutdown/Trip
OP SENSOR OPEN	Alarm Description
<b>ALARMS 6-2</b>	Second Alarm Screen
ALARMS:(02/02)	Total Alarms
SHUTDOWN ALARM	Alarm Type: Warn/Shutdown/Trip
GEN FAIL TO CLOSE	Alarm Description







**7.1.7 EVENT LOG**









EVENTS 7-1	First Event Log Screen
RECORDS: (01/02)	Total Records
OVER POWER TRIP	Fault Type
2010-12-18 21:31:55	Record Time
EVENTS 7-2	Second Event Log Screen
RECORDS: (02/02)	Total Records
GEN FAIL TO CLOSE	Fault Type
2010-12-18 08:11:07	Record Time

**7.1.8 "ABOUT" DISPLAY**

ABOUT 8-1	First About Screen
MODEL: HGM6510	Model Type
SOFTWARE:V4.0.2	Software Version
11-03-08 (2) 03:11:32	Current Time
ABOUT 8-2	Second About Screen
HARDWARE: V1.3	Hardware Version
CPU TEMP:37°C/98°F	Inner Temperature
ISSUE DATE: 2011-06-24	Issue Time

**7.2 PARAMETER CONFIGURATION**

Press and hold  and then press  to enter into password screen. Use  and  to increase/decrease values and input the corresponding password 0~9; Use  or  to move the cursor; after you have input the fourth digit press  to verify the password. If the password is correct, you will enter into parameter setting menu; otherwise you will exit directly. (Factory default password is 1234 and it can be changed by users).

Press  and  to scroll screen; select parameter you want to configure and press  key (the parameter will highlight with black), press  key or  key to change parameter value, press  or  to move the cursor and press  to confirm setting.

During parameter configuration, pressing  will exit the interface directly and return to the main screen.

**Parameters list:**

Parameter	Range	Default	Notes
01 Low Oil Pressure (Warn)	(1-999)kPa	124kPa/18.0PSI	Return value: 138kPa/20.0PSI
02 Low Oil Pressure (Shutdown)	(0-997)kPa	103kPa/14.9PSI	Setting standard: Shutdown value<Warn value<Return value
03 High Temperature (Warn)	(81-139)°C	90°C/194°F	Return value: 88°C/190°F
04 High Temperature (Shutdown)	(82-140)°C	95°C/203°F	Setting standard: Shutdown value<Warn value<Return value
05 Low Fuel Level (Warn)	(0-100)%	10%	Analogue value
06 Start Delay	(0-9999)s	5s	Timer
07 Preheat Delay	(0-300)s	0s	Timer
08 Cranking Time	(3-60)s	8s	Timer
09 Crank Rest Time	(3-60)s	10s	Timer
10 Safety On Time	(1-60)s	10s	Timer
11 Over Speed/ Overshoot delay	(0-10)s	2s	Timer
12 Start Idle Time	(0-3600)s	10s	Timer
13 Warming Up Time	(0-3600)s	30s	Timer
14 Stop Delay	(0-9999)s	30s	Timer
15 Cooling Time	(0-3600)s	60s	Timer
16 Stop Idle Time	(0-3600)s	10s	Timer
17 ETS Solenoid Hold	(0-120)s	2s	Timer
18 Fail to Stop Delay	(10-120)s	30s	Timer
19 Generator Transient Delay	(0-30)s	5s	Timer
20 Battery Under Volt Delay	(0-9999)s	60s	Timer
21 Battery Over Volt Delay	(0-9999)s	60s	Timer
22 Reverse Power Delay	(0-300)s	10s	Timer
23 Generator Under Volt (Warn)	(50-1300)V	196V	On-load value: 207V Setting standard: Shutdown value<Warn value<On-load value
24 Generator Under Volt (Shutdown)	(50-1300 )V	184V	Generator under voltage shutdown value
25 Generator Over Volt (Warn)	(50-1300)V	265V	Return value: 253V
26 Generator Over Volt (Shutdown)	(50-1300)V	273V	Setting standard: Shutdown value>Warn

## HGM6510 GENSET PARALLEL UNIT

Parameter	Range	Default	Notes
			value>Return value
27 Generator Under Frequency (Warn)	(0.1-74.9)Hz	42.0Hz	On-load value: 45.0Hz Setting standard: Shutdown value<Warn value<On-load value
28 Generator Under Frequency (Shutdown)	(0-74.8)Hz	40.0Hz	Generator under frequency shutdown value
29 Generator Over Frequency (Warn)	(0.1-74.9)Hz	55.0Hz	Return value: 52.0Hz
30 Generator Over Frequency (Shutdown)	(0.2-75)Hz	57.0Hz	Setting standard: Shutdown value>Warn value>Return value
31 Over Current	(50-120)%	100%	Analogue Value
32 Flywheel Teeth	(10-500)	118	Tooth number of the engine ; for judging of starter disconnect conditions and detection of engine speed.
33 Under Speed (Warn)	(1-5999)RPM	1350RPM	On-load value: 1380RPM Setting standard: Shutdown value<Warn value<On-load value
34 Under Speed (Shutdown)	(0-5998)RPM	1270RPM	Under speed shutdown Value
35 Over Speed (Warn)	(1-5999)RPM	1650RPM	Return value: 1620RPM
36 Over Speed (Shutdown)	(2-6000)RPM	1710RPM	Setting standard: Shutdown value>Warn value>Return value
37 Over Speed Shoot	(0-10)%	10	Analogue Value
38 Battery Under Volt (Warn)	(0-39.9)V	8.0V	Return Value: 9.0V
39 Battery Over Volt (Warn)	(0.1-40)V	33.0V	Return Value: 32 V
40 Charge Alternator Failure (Warn)	(0-39)V	6.0V	Analogue Value
41 Language Select	(0-2)	0	0:Chinese; 1:English 2: Espanol
42 Password	(0-9999)	1234	Numerical Value
43 Priority	(0-19)	0	The smaller the number, the higher the priority.
44 Module Address (RS485)	(1-254)	1	RS485 communication address
45 CT	(5-6000):5A	500A	Load Current: 500A
46 Rated Active Power	(0-6000)	345	Unit: kW
47 Rated Reactive Power	(0-6000)	258	Unit: kVar

HGM6510 GENSET PARALLEL UNIT











Parameter	Range	Default	Notes
48 Load Ramp Rate	(0-100)%	3%	Load/unload speed %/s
49 Full Power	(0-100)%	80%	Schedule other gen-sets' start load percentage
50 Low Power Shutdown	(0-99)%	50%	Schedule other gen-sets' stop load percentage
51 Positive Freq Difference	(0-2)Hz	0.2Hz	Frequency difference between the generator and the bus. If it is lower than the positive value and higher than the negative value, then it is considered as synchronization.
52 Negative Freq Difference	(0-2)Hz	0.1Hz	
53 Voltage Difference	(0-30)V	3V	Voltage difference between generator and bus.
54 Phase Angle Difference	(0-20)°	10°	Initial phase difference between generator and bus.
55 Fail to Sync Delay	(5-300)s	60s	If after synchronization is initiated, the gen-set fails to synchronize after the delay has expired, "Fail to Sync" alarm will be initiated.
56 MSC Baud Rate	(0-2)	0	Baud rate of MSC 0:330K 1:250K 2:125K

**Other parameters configuration (can only be configured via PC software)**

Parameter	Default Value
Module Address	1
Alternator Selection	Yes
Poles	4
Magnetic Pickup	Yes
Quick On-load Mode	No
Start Times	3
Voltage Transformer	No
Fuel Pump Control	No
Input 1	Remote start on-load demand; close to activate
Input 2	Low oil pressure; close to activate; active period: from safety on.
Input 3	High temperature; close to activate; active period: from safety on.
Input 4	Generator Closed Auxiliary; close to activate
Input 5	Indication, close to activate
Input 6	Working mode selection, close to activate
Input 7	Indication, close to activate
Input 8	Indication, close to activate
Input 9	Indication, close to activate
Output 1	Generator Voltage Normal
Output 2	Common alarm
Output 3	Idle/high speed control
Output 4	Close Generator Pulse
Output 5	Open Generator Pulse
Generator Rated Frequency	50.0Hz
Generator Rated Voltage	230V
LED1	System in <b>AUTO</b> mode
LED2	Fail to start
LED3	Common shutdown
LED4	Common alarm
Delayed Over Current	100%(500A)
Time multiplier	36
Over Current Action	Trip and Stop
Crank Disconnect Generator Frequency	15Hz
Crank Disconnect Engine Speed	450RPM
Crank Disconnect Oil Pressure	Not used
Detect Oil Pressure During Cranking	No
Scheduled Start	No
MSC ID	0
GOV Settings	0V
AVR Settings	0V

Synch Frequency PID Settings	Configured via HGM6500 PC software.
Synch Voltage PID Settings	
Active Power PID Settings	
Reactive Power PID Settings	

### 7.3 DATE/TIME SETTING

Press  and  simultaneously to enter into date/time setting interface. The first digit of the fourth row will be highlighted with black. Press  or  to increase/decrease the value and input the corresponding password 0~9; press  or  to move cursor left or right; press  after altering the last digit, and then press  to save settings and exit. Press  without press  to exit directly without saving.

Date and time order: Year-Month-Date (Week) Hour-Minute-Second

 **NOTE:** Parameters and the date/time must be configured in **STOP** mode only.

### 7.4 DATA DISPLAY

#### 7.4.1 BASIC DISPLAY

Engine Speed  
 Engine Oil Pressure  
 Coolant Temperature  
 Fuel Level  
 Battery voltage/Charge Alt Voltage  
 Total Run Time/Start Times  
 Remaining Maintenance Time  
 Generator Phase Voltage (L1-N, L2-N, L3-N)  
 Generator Line Voltage (L1-L2, L2-L3, L3-L1)  
 Generator Frequency  
 Load/Generator Current (L1, L2, L3)  
 Generator Split Phase Active Power (L1, L2, L3)  
 Generator 3-phase Total Active Power  
 Each Phase Power Factor (L1, L2, L3)  
 Average Power Factor  
 Single Generator Reactive Power (L1, L2, L3)

Generator 3-phase Total Reactive Power  
Generator Total Active/Reactive/Apparent Energy  
Generator Phase Sequence  
Bus Phase Voltage (L1-N, L2-N, L3-N)  
Bus Line Voltage (L1-L2, L2-L3, L3-L1)  
Bus Frequency  
Bus Phase Sequence

**7.4.2 ECU DISPLAY**

Engine Oil Temperature  
Coolant Pressure  
Inlet Temperature  
Exhaust Temperature  
Turbo Temperature  
Fuel Pressure  
Fuel Consumption  
Total Fuel Consumption

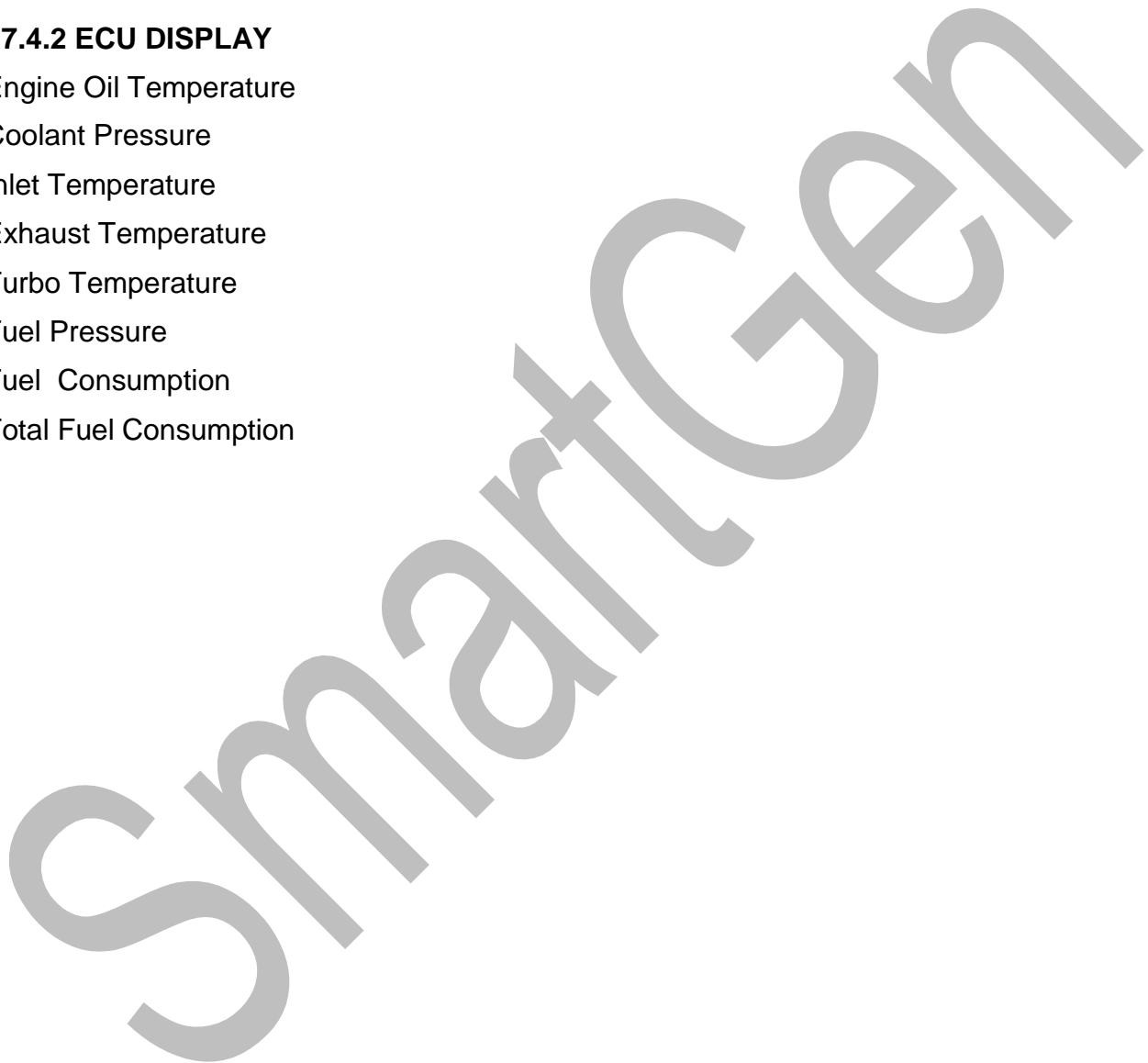

## 8 INPUT AND OUTPUT PORTS CONFIGURATION

### 8.1 CONFIGURABLE INPUT PORTS 1~9

No.	Type	Description
0	User configured	Including following functions, Indication: indicate only, not warning or shutdown. Warning: warn only, not shutdown. Shutdown: alarm and shutdown immediately Trip and stop: alarm, generator unloads and shutdown after hi-speed cooling Never: input inactive. Always: input is active all the time. From crank: detecting as soon as start. From safety on: detecting after safety on delay.
1	Alarm Mute	Can prohibit "Audible Alarm" output when the input is active.
2	Alarm Reset	Can reset shutdown alarm and trip alarm when the input is active.
3	Alternative Frequency	For engines fitted with ECU CANBUS. When active, 60Hz is selected.
4	Alternative Voltage	For engines fitted with ECU CANBUS
5	Auto Restore Inhibit	In AUTO mode, after the normal running of generator, when the input is active, automatic stop will not be allowed.
6	Auto Start Inhibit	In AUTO mode, when the input is active, automatic start will not be allowed.
7	Auxiliary Mains Fail	Reserved
8	Generator Auxiliary Close	Connect to auxiliary contact of generator breaker.
9	Generator Load Inhibit	Prohibit genset to close when the input is active.
10	Droop Enable	For engines fitted with ECU CANBUS. When active, droop is allowed.
11	Lamp Test	When the input is active, all LED indicators will be illuminated.
12	Mains Closed Auxiliary	Reserved
13	Mains Closed Inhibit	Reserved
14	Panel Lock	When the input is active, all function buttons are inactive.
15	Remote Start (Off load )	In Auto mode, when the input is active, the genset can be started automatically and NOT take load after genset normal running; when the input is inactive, genset will stop automatically.
16	Remote Start (On-load )	In Auto mode, when the input is active, the genset can be started automatically, parallel with the bus and share load after genset normal running; when the

HGM6510 GENSET PARALLEL UNIT

		input is inactive, the gen-set will automatically open and stop.
17	Remote Start On Load Demand	In Auto mode, when the input is active, all the parallel units are started in the order of priority; then according to the load, the number of units is automatically increased or decreased.
18	Scheduled Run Inhibit	In Auto mode, when the input is active, schedule start is inhibited.
19	Simulate Available Mains	Reserved
20	Simulate Button AUTO	External pushbuttons (not self-locking switch) can be connected to simulate panel pushbuttons.
21	Simulate Button MANUAL	
22	Simulate STOP Button	
23	Simulate Test Button	
24	Simulate START Button	
25	Transfer to Bus	
26	Transfer to generator	
27	MSC Alarm inhibit	When MSC is disconnected or data error occurs, alarm signal will be prohibited.
28	Duty Select	When the input is active, priority is the highest; used to select main/standby generator.
29	Reset Alarm Maintenance	When the input is active, the controller will reset maintenance time to its pre-set value and clear the alarm.
30	Remote Start in Island Mode	Reserved
31	Mains Parallel Mode	When the input is active, the generator power output is constant (output power value is defined via PC software) and will not share load with other generators.
32	Speed Raise	Used in mains parallel mode, inching input; when the input is active, increase generator active power output by 1%.
33	Speed Lower	Used in mains parallel mode, inching input; when the input is active, decrease generator active power output by 1%.
34	Voltage Raise	Used in mains parallel mode, inching input; when the input is active, increase generator reactive power output by 1%.
35	Voltage Lower	Used in mains parallel mode, inching input; when the input is active, decrease generator reactive power output by 1%.
36	Black Start Input	When the input is active: a) Generator transfer failure alarms will not be detected; b) When start the gen-set, generator closed output is

		simultaneously activated to control the breaker closed. Used in case of transformer load to avoid over current shutdown when the generator is closed.
37	Auto Mode Input	When the input is active, the controller is in auto mode and other modes are disabled.
38	Disable Shutdown	When the input is active, all the shutdown alarms are disabled.
39	Monitor Mode Input	When the input is active, LCD shows “monitor mode”; genset start and stop are not controlled in this mode and only genset parameters are monitored.
40	Power manager mode	When the input is active, LCD shows “power management mode”; in this mode, the controller could not start/stop the gen-set, it is only responsible for synchronization, power sharing, schedule start/stop and breaker opening/closing.
41	Reserved	

**NOTE:** Do not prescribe the same function to configurable inputs 1-9 (except for “Not Used” and “User-defined”), otherwise incorrect operation can occur.

## 8.2 CONFIGURABLE OUTPUT PORTS 1-5

All output ports have the same options, similar functions can be prescribed to several output ports.

No.	Type	Description
00	Output Not Used	
01	Air Flap Relay	Action when over speed shutdown and emergence stop. It also can close the air inflow to stop the engine as soon as possible.
02	Audible Alarm	Action when warning, shutdown, trips. Can be connected annunciator externally. When “alarm mute” input is active, this output is disabled.
03	Battery High Volts	Action when battery over voltage warning alarm.
04	Battery Low Volts	Action when battery under voltage warning alarm.
05	Digital Input 7 Active	Action when input port 7 is active
06	Digital Input 8 Active	Action when input port 8 is active
07	Digital Input 9 Active	Action when input port 9 is active
08	Start Relay Output	Action when genset is cranking and disconnect when crank successful.
09	Fuel Relay Output	Action when genset is starting and disconnect when stop is completed.
010	Calling for Scheduled On	Action when scheduled start is activated and gen-set is running (Auto mode)
011	Charging Alternator Failure	Action when generator charging failure warning alarm.
012	Close Generator	Control generator to take load. ( Continuous active)

HGM6510 GENSET PARALLEL UNIT

No.	Type	Description
013	Close Generator Pulse	Generator impulse close output; output time depends on impulse time.
014	Close Mains	Control mains to take load. ( Continuous active)
015	Close Mains Pulse	Mains impulse close output; output time depends on impulse time.
016	Common Under/Over Freq. Shutdown	Action when under frequency or over frequency shutdown alarm
017	Common Under/Over Freq. Warn	Action when under frequency or over frequency warning alarm
018	Common Under/Over Voltage Shutdown	Action when under/over voltage shutdown alarm.
019	Common Under/Over Voltage Warn	Action when under/over voltage warning alarm.
020	Common Alarm	Action when generator common warn, common shutdown, common trip alarm.
021	Common Electrical Trip Alarm	Action when common trip alarm.
022	Common Shutdown Alarm	Action when common shutdown alarm.
023	Common Warn Alarm	Action when common warning alarm.
024	Coolant Temp. High Pre-alarm for 1#	Action when high water/cylinder temperature warning alarm.
025	Coolant Temp. High Shutdown for 1#	Action when high water/cylinder temperature shutdown alarm.
026	Cooling Timer in Progress	Action during cooling delay
027	Check Sync Output	Action during synchronization
028	Digital Input 1 Active	Action when input port 1 is active.
029	Digital Input 2 Active	Action when input port 2 is active.
030	Digital Input 3 Active	Action when input port 3 is active.
031	Digital Input 4 Active	Action when input port 4 is active.
032	Digital Input 5 Active	Action when input port 5 is active.
033	Digital Input 6 Active	Action when input port 6 is active.
034	Emergency Stop	Action when emergency shutdown alarm.
035	Energize to Stop	Action during ETS delay
036	Fail To Start	Action when fail to start alarm.
037	Fuel Pump Control	It is controlled by fuel pump of level sensor's limited threshold.
038	Generator Available	Action when the generator is on-load and during cooling down.
039	Generator High Freq. Pre-alarm	Action when generator over frequency warning alarm.
040	Generator High Freq. Shutdown	Action when generator over frequency shutdown alarm.

## HGM6510 GENSET PARALLEL UNIT

No.	Type	Description
041	Generator High Voltage Pre-alarm	Action when generator over voltage warning alarm.
042	Generator High Voltage Shutdown	Action when generator over voltage shutdown alarm.
043	Generator Low Freq. Pre-alarm	Action when generator under frequency warning alarm.
044	Generator Low Freq. Shutdown	Action when generator under frequency shutdown alarm.
045	Generator Low Voltage Pre-alarm	Action when generator under voltage warning alarm.
046	Generator Low Voltage Shutdown	Action when generator under voltage shutdown alarm.
047	Louver Control	Action when the genset is starting and disconnect when genset is stopped completely.
048	Low Fuel Level	Action when low fuel level alarms.
049	Loss of Speed	After safety on delay, action if the controller detects that engine speed is equal to 0.
050	Mains Failure	Action when mains over frequency, under frequency, over voltage, under voltage or auxiliary mains abnormal input is active.
051	Mains High Frequency	Action when mains over frequency.
052	Mains High Voltage	Action when mains over voltage.
053	Mains Low Frequency	Action when mains under frequency.
054	Mains Low Voltage	Action when mains under voltage.
055	Oil Pressure Low Pre-alarm for 1#	Action when low oil pressure warning alarm.
056	Oil Pressure Low Shutdown for 1#	Action when low oil pressure shutdown alarm.
057	Oil Pressure Sensor Open Circuit	Action when oil pressure sensor is open circuit.
058	Open Generator	Control generator to off load.
059	Open Generator Pulse	Generator impulse open output, output time is depends on impulse time.
060	Open Mains	Control generator to off load.
061	Open Mains Pulse	Mains impulse open output, output time is depends on impulse time.
062	Over Current Pre-alarm	Action when generator over current warning alarm.
063	Over Current Trip	Action when generator over current trip alarm.
064	Over Speed Pre-alarm	Action when engine over speed warning alarm.
065	Over Speed Shutdown	Action when engine over speed shutdown alarm.

## HGM6510 GENSET PARALLEL UNIT

No.	Type	Description
066	Preheat (during pre-heat timer)	Action from preheat delay till the start of cranking.
067	Preheat (until end of crank)	Action from preheat delay till the end of cranking.
068	Preheat (until end of warm timer)	Action from preheat delay till the end of warming up.
069	Preheat (until safety on)	Action from preheat delay till the end of safety on time.
070	Open Output	Control generator or mains to off load.
071	System in Test Mode	Action when the system is in the test mode.
072	System in Auto Mode	Action when the system is in the Auto mode.
073	System in Manual Mode	Action when the system is in the manual mode.
074	System in Stop Mode	Action when the system is in the stop mode.
075	Under Speed Pre-alarm	Action when under speed warning.
076	Under Speed Shutdown	Action when under speed shutdown.
077	Reserved	
078	Idle/High-Speed Control	Action from "Cranking" delay to "Start Idle" delay and from "Stop Idle" delay to "Fail to Stop" delay.
079	Pre-oil Supply Output	Action from "Cranking" delay to "Safety On" delay.
080	Raise Speed Energized	Reserved
081	Excite Generator	Action when cranking; During safety on running, output 2s if there is no generator frequency.
082	Drop Speed Energized	Reserved
083	Preset to Lubricate	Action from "Preheat" delay to "Safety On" delay.
084	Raise Volt. Output	Reserved
085	Drop Volt. Output	Reserved
086	Reverse Power Output	When the generator reverse power has exceeded the pre-set value, the output activates.
087	Over Power Output	When the generator over power has exceeded the pre-set value, the output activates.
088	Low Water Temperature Warn	Action when low temperature warning.
089	Generator Volt. Normal	Action when generator voltage is normal.
090	ECU Power	For engines fitted with ECU; Used for control ECU power supply.
091	ECU Stop	For engines fitted with ECU; Used for control ECU shutdown.

 **NOTE: Functions of 1~5 output ports only can be configured via PC software.**

## 9 EVENT LOG

HGM6510 controller can save a maximum of 99 event logs, including shutdown type, date and time (warning alarms are not recorded). Once the log is full (99 records), any subsequent shutdown entry will overwrite the oldest entry in the log, so the log will always contain the 99 most recent abnormal events.

## 10 BACK PANEL

HGM6510 controller back panel is shown below:

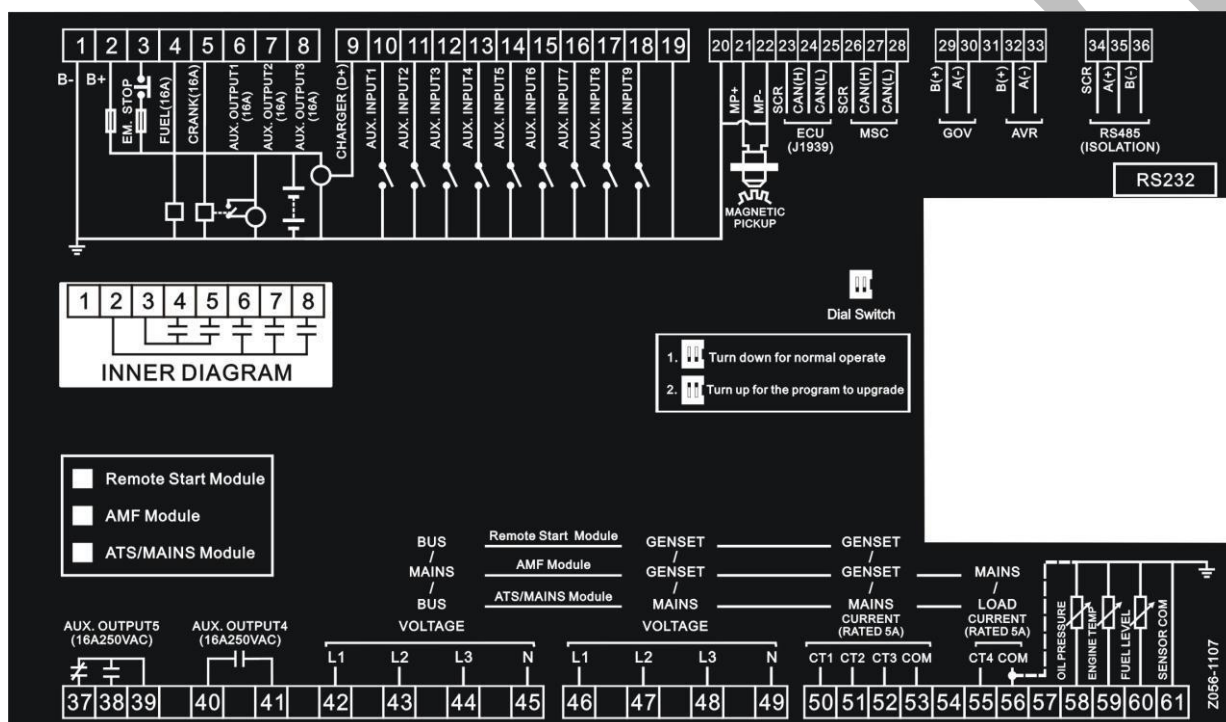

### Terminal connections description

Pin	Function	Cable Size	Description
1	B-	2.5mm <sup>2</sup>	DC power supply negative input. Connected with negative of starter battery.
2	B+	2.5mm <sup>2</sup>	DC power supply positive input. Connected with positive of starter battery. Max. 20A fuse is recommended.
3	Emergency Stop	2.5mm <sup>2</sup>	Connected with DC power supply via emergency stop button. Also supply power to fuel relay and start relay. Max. 30A fuse is recommended.
4	Fuel Relay Output	2.5mm <sup>2</sup>	DC power is supplied by terminal 3, rated 16A
5	Crank	2.5mm <sup>2</sup>	DC power is supplied by terminal 3, rated 16A

HGM6510 GENSET PARALLEL UNIT

Pin	Function	Cable Size	Description
6	Aux. Output 1	2.5mm <sup>2</sup>	B+ output, rated 16A
7	Aux. Output 2	2.5mm <sup>2</sup>	B+ output, rated 16A
8	Aux. Output 3	2.5mm <sup>2</sup>	B+ output, rated 16A
9	Charger(D+)	1.0mm <sup>2</sup>	Connected with charger starter's D+ terminal. Ground connected is not allowed.
10	Aux. Input 1	1.0mm <sup>2</sup>	Digital input
11	Aux. Input 2	1.0mm <sup>2</sup>	Digital input
12	Aux. Input 3	1.0mm <sup>2</sup>	Digital input
13	Aux. Input 4	1.0mm <sup>2</sup>	Digital input
14	Aux. Input 5	1.0mm <sup>2</sup>	Digital input
15	Aux. Input 6	1.0mm <sup>2</sup>	Digital input
16	Aux. Input 7	1.0mm <sup>2</sup>	Digital input
17	Aux. Input 8	1.0mm <sup>2</sup>	Digital input
18	Aux. Input 9	1.0mm <sup>2</sup>	Digital input
19	Common GND(B-)	1.0mm <sup>2</sup>	Connected with enclosure or negative of starter battery.
20	Magnetic Pickup	1.0mm <sup>2</sup>	Connect to speed sensor
21	Magnetic Pickup +	1.0mm <sup>2</sup>	
22	Magnetic Pickup -	1.0mm <sup>2</sup>	
23	CAN J1939 SCR	0.5mm <sup>2</sup>	Impedance-120Ω shielding wire is recommended.
24	CAN J1939 (H)	0.5mm <sup>2</sup>	
25	CAN J1939 (L)	0.5mm <sup>2</sup>	
26	MSC SCR	0.5mm <sup>2</sup>	Use 120Ω shielding wire to connect all parallel HGM6510 controllers together.
27	MSC (H)	0.5mm <sup>2</sup>	
28	MSC (L)	0.5mm <sup>2</sup>	
29	GOV Wire B (+)	1.0mm <sup>2</sup>	2-core shielded wire is recommended, shielding layer connected to the ground at GOV end.
30	GOV Wire A (-)	1.0mm <sup>2</sup>	
31	Not Used		
32	AVR Wire B (+)	1.0mm <sup>2</sup>	2-core shielded wire is recommended, shielding layer connected to the ground at AVR end.
33	AVR Wire A (-)	1.0mm <sup>2</sup>	
34	RS485 SCR	0.5mm <sup>2</sup>	PC programming or monitoring port (Opto-isolation); its single-end earthed.
35	RS485 A (-)	0.5mm <sup>2</sup>	
36	RS485 B (+)	0.5mm <sup>2</sup>	
37 38 39	Aux. Output 5	2.5mm <sup>2</sup>	Normally open/close volts free contactor. Rated 16A.
40 41	Aux. Output 4	2.5mm <sup>2</sup>	Normally open volts free contactor. Rated 16A.
42	Bus A Phase Voltage Sensing Input	1.0mm <sup>2</sup>	Connected to A-phase of bus (2A fuse is recommended)
43	Bus B Phase Voltage Sensing Input	1.0mm <sup>2</sup>	Connected to B-phase of bus (2A fuse is recommended)

HGM6510 GENSET PARALLEL UNIT

Pin	Function	Cable Size	Description
44	Bus C Phase Voltage Sensing Input	1.0mm <sup>2</sup>	Connected to C-phase of bus (2A fuse is recommended)
45	Bus N-wire input	1.0mm <sup>2</sup>	Connected to N-wire of bus
46	Genset A Phase Voltage Sensing Input	1.0mm <sup>2</sup>	Connected to A-phase of genset (2A fuse is recommended)
47	Genset B Phase Voltage Sensing Input	1.0mm <sup>2</sup>	Connected to B-phase of genset (2A fuse is recommended)
48	Genset C Phase Voltage Sensing Input	1.0mm <sup>2</sup>	Connected to C-phase of genset (2A fuse is recommended)
49	Genset N-wire input	1.0mm <sup>2</sup>	Connected to N-wire of genset
50	C.T. A Phase Sensing Input	2.5mm <sup>2</sup>	Outside connected to secondary coil of current transformer(rated 5A)
51	C.T. B Phase Sensing Input	2.5mm <sup>2</sup>	Outside connected to secondary coil of current transformer(rated 5A)
52	C.T. C Phase Sensing Input	2.5mm <sup>2</sup>	Outside connected to secondary coil of current transformer(rated 5A)
53	C.T. COM	2.5mm <sup>2</sup>	Outside connected to C.T. common port; this port must be connected to negative of battery or ground at the same time.
54	Not Used		
55	Load C.T. Sensing Input	2.5mm <sup>2</sup>	Outside connected to secondary coil of current transformer (Maximum 5A). HGM6520 Only.
56			
57	Not Used		
58	Oil Pressure Sensor	1.0mm <sup>2</sup>	Outside connected to a resistance type sensor.
59	Temperature Sensor	1.0mm <sup>2</sup>	Outside connected to a resistance type sensor.
60	Fuel Level Sensor	1.0mm <sup>2</sup>	Outside connected to a resistance type sensor.
61	Sensor COM	1.0mm <sup>2</sup>	Sensor common ground terminal; connect to genset enclosure or negative of starter battery.
	RS232 Port		PC programming or monitoring port; do not use this port and RS485 port at the same time.
	DIP Switch	2-bit	For upgrading program 1. Dial up for normal use; 2. Dial down for upgrading program

## 11 ECU INTERFACE

**HGM6510** controller is fitted with ECU interface. As different manufactories use different ports and communication protocols, please check if the controller is suitable for your engine.

This controller can monitor and control some parameters of the engine, such as engine speed, oil pressure, temperature. These parameters can be monitored by standard communication port and there is no need to install corresponding sensors, which can reduce wiring and enhance reliability.

Please refer to **HGM6500 Parallel Scheme** for more information about engine ports.

## 12 DEBUGGING PROCEDURE

### 12.1 STEP 1. SINGLE UNIT DEBUGGING

- 1) Check the parameter configuration of the controller;
- 2) Check the gen-set wirings and MSC CAN wirings between the units. (E.g. if 3 generators are correctly connected, HGM6510 LCD status screen 1-4 will display Module Number: 3. See the picture on the right).
- 3) Start the genset manually, check if the engine and generator parameters are normal;
- 4) Start the genset manually, check if breaker opens and closes normally;
- 5) Start the genset manually, after closing the breaker check if generator frequency can be adjusted to the rated frequency (e.g. set the rated frequency as 52Hz/48Hz);
- 6) Start the genset manually, after closing the breaker check if generator voltage can be adjusted to the rated voltage (e.g. set the rated voltage as 240V/220V);
- 7) Start the genset manually (on-load) , check if power factor, active power and reactive power are normal; if there is negative value, then check phase sequence of generator voltage and current, current transformer incoming line direction, current transformer secondary current dotted terminal;
- 8) Start the genset manually, do performance tests on single unit according to the national standards.

	Status	1-4
Module Number	3	
Module ID	012	
Priority	012	

**▲ Note: Please refer to *HGM6500 Parallel Scheme List* for more information about GOV and AVR settings.**

## 12.2 STEP 2: MANUAL PARALLEL OPERATION OFF-LOAD

- 1) Close breaker and parallel gensets manually, check that the units synchronization parallel is smooth and steady and breaker close impulse current is not too high;
- 2) After gensets parallel operation off load, check that there is no high circumfluence on HGM6510 current screen;
- 3) After gensets parallel operation off load, check if the output of active and reactive power is equal to 0; if it is not, then check if there is power oscillation; if there is, adjust the gain and stability values of HGM6510 controller, or adjust engine GOV or generator AVR gain and stability potentiometer to avoid active and reactive power oscillation; output is close to 0.

## 12.3 STEP 3: MANUAL PARALLEL OPERATION ON-LOAD

- 1) Parallel the gensets manually, perform on-load test and check if active and reactive power is evenly distributed between all the gensets;
- 2) Parallel the gensets manually, perform ramp on-load test to see if there is high overshoot or power oscillation during this period; if there is, regulate Load Rampx%/s via PC software;
- 3) Parallel the gensets and on-load manually, perform ramp off-load test to see if gen-set breaker opens after reaching minimum load threshold (%);
- 4) Parallel the gensets manually, perform impact load test and impact off-load test to check if there is power oscillation.

## 12.4 STEP 4: FULLY AUTOMATIC PARALLEL OPERATION

When the controller is in auto mode, if “remote start on-load demand” is active, it will carry out fully automatic parallel operation, start and stop according to the users’ requirement. There are 3 ways of automatic parallel operation:

- 1) Start on-load demand: the module with the highest priority starts firstly. When load exceeds the pre-set start maximum percentage, the second according to the priority module will start the gen-set, synchronize and share load. When load falls lower than the preset minimum stop percentage, after stop delay the second module breaker will be open and the module will be cooled down and stopped.
- 2) Start all sets initially: all the modules start at the same time; the first module to reach load condition closes first; when other modules reach load condition, they synchronize one by one. After that the modules monitors the load; If load value falls

below module pre-set shutdown minimum percentage, the module with lowest priority enters stop delay and then cools down and stops. If load exceeds the preset start maximum percentage, the generators that are at rest will all start again.

- 3) Balanced engine running time: Engine with the lowest total run time starts first. When the running gen-set total run time exceeds the other genset balanced running time, then the genset with the next lowest total run time starts (both “start on-load demand” or “start all sets initially” modes are possible); other gensets after synchronization and parallel operation, then opening breaker, unloading and stop automatically. All the gen-sets are repeatedly started and stopped according to their total run time.

SmartGen

### 13 POWER MANAGEMENT MODE

Power management mode can be selected via configurable input ports.

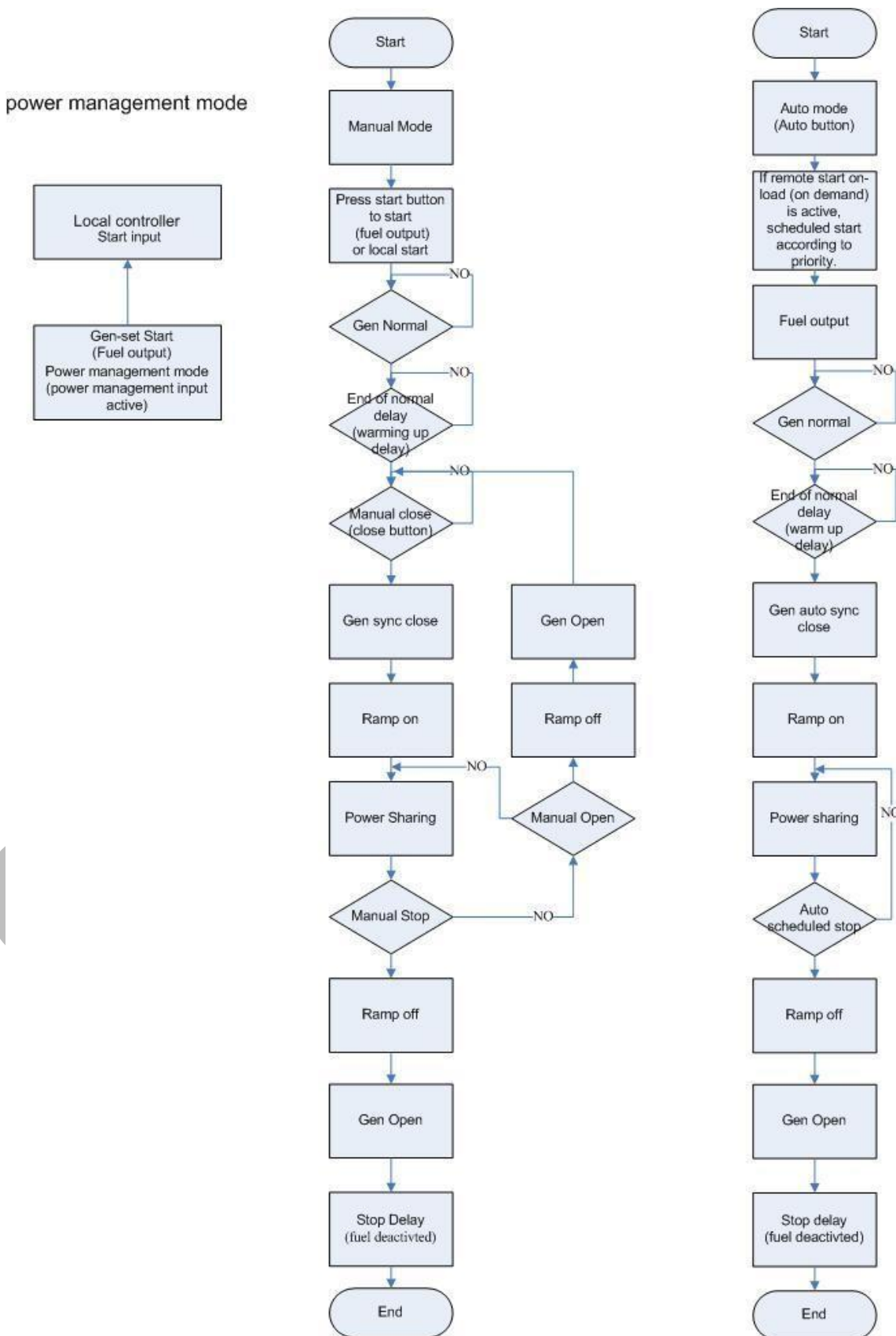

## 14 TROUBLESHOOTING

Problem	Possible Solution
Controller does not respond to power on	Check starting batteries; Check the wiring to the controller; Check the DC fuse. Check that HGM6510 controller DIP switch on back panel is in the right position: Dial up for normal use; Dial down for upgrading program.
Genset shutdown	Check that water/cylinder temperature is not too high; Check alternator voltage; Check the DC fuse.
Emergency shutdown	Check emergency shutdown button functions; Check if the starting battery positive is correctly connected to the emergency stop input; Check that there is no open circuit.
Low oil pressure alarm after crank success	Check the oil pressure sensor and its wiring.
High water temperature alarm after crank success	Check the temperature sensor and its wiring.
Shutdown alarm during running	Check corresponding breaker and its wiring according to the information on LCD; Check auxiliary input port.
Generator fails to close	Check ATS auxiliary input port; Check generator close relay.
Generator Reverse Phase	Check generator voltage phase sequence.
Bus Reverse Phase	Check bus voltage phase sequence.
Generator Reverse Power	Check if the GOV and AVR are normal; Check if the CT primary wiring and secondary wiring are correct; Check if the voltage/current phase sequences are correct.
MSC ID Error	MSC ID of the controller is repetitive to another ID. Try to reset MSC ID using PC software again.
MSC Data Error	Check connections of CAN high and low polarity; Check if correctly connected of 120Ω resistor;
Fail to start	Check fuel return circuit and its connections; Check starter batteries; Check speed sensor and its connections; Refer to engine manual.
Starter motor does not respond	Check starter connections; Check starter batteries.
Gen-set is running, but ATS does not close	Check ATS; Check ATS and controller connections; Check if configure input port as "Generator Load Inhibit"; Check if generator voltage has reach on-load requirement.

# 15 TYPICAL WIRING DIAGRAMS

## 15.1 HGM6510 TYPICAL WIRING DIAGRAM

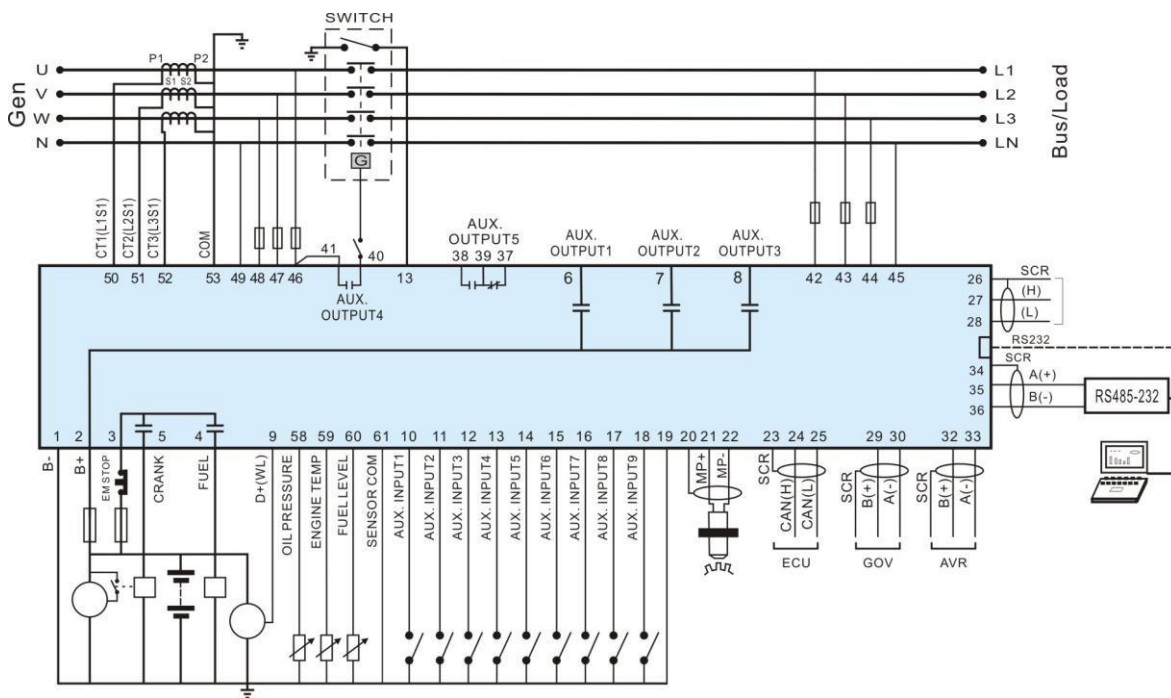

**NOTE:** Expansion high-capacity relays for start and fuel output ports are recommended.

## 15.2 HGM6510 MAINS PARALLEL APPLICATION

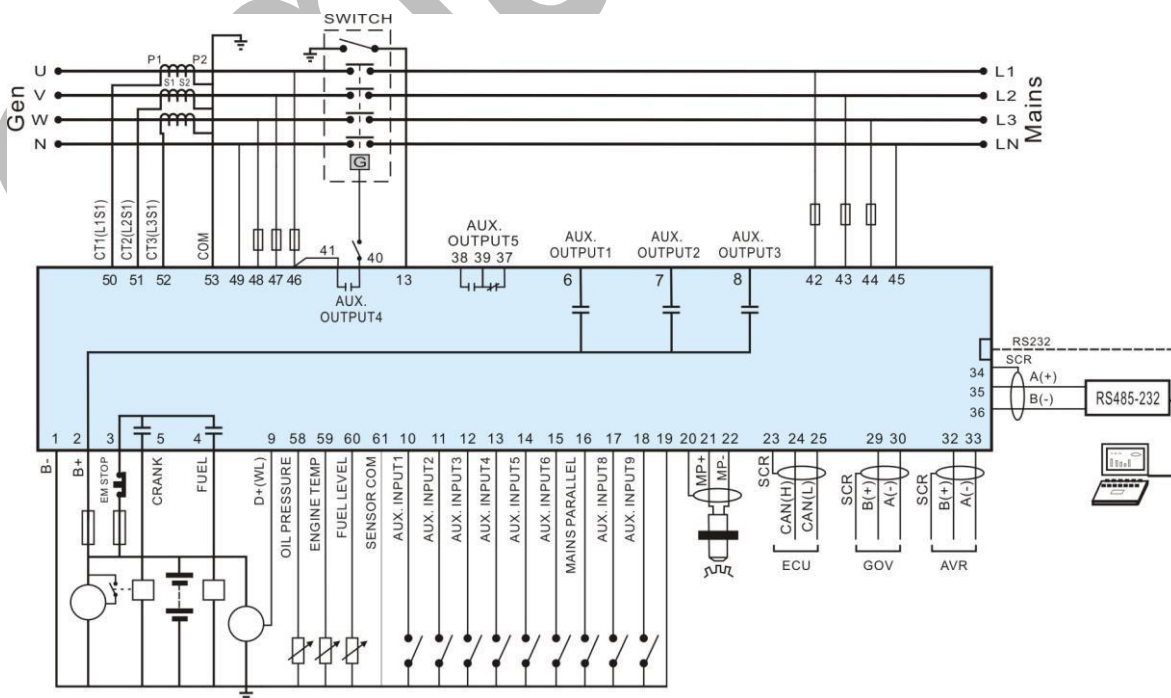

7

031 Mains parallel mode Close to activate

**Load control**

Load parallel ramp minimum

Setting value: 0.0%(0.0 KW) Current reading: 0.0%(0.0 KW)

Load model

Mode select: Bus Current reading: Bus

Active power: 18.0%(62.1KW) Current reading: 0.0%(0.0 KW)

Reactive power:  kVar 0.0%(0.0kVar 1.00 lag) Current reading: 0.0%(0.0kVar 0.00 lag)

pf

**15.3 HGM6510 MULTI-SET PARALLEL APPLICATION**

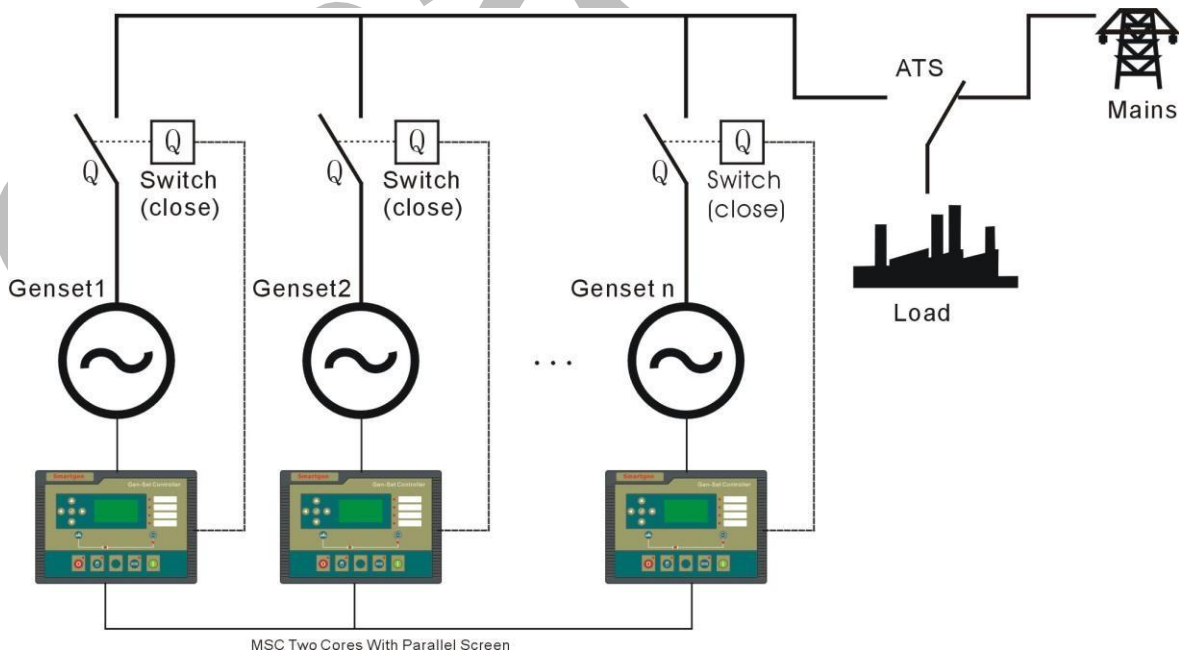

## 16 COMMUNICATION INTERFACE

The controller is fitted with both standard RS232 and RS485 communication interfaces, so computer can directly (or through a modem) communicate with controller and perform remote start/stop, data monitoring and other functions.

RS232/485 interface uses MODBUS communication protocol. MODBUS is a master-slave protocol, and the controller acts as a slave. When the controller receives a request from the host (PC or monitoring host), it sends defined format data to the host. The controller never sends data to the host actively.

## 17 CASE DIMENSIONS AND PANEL CUTOUT

